

MA10/4

Electronic Display

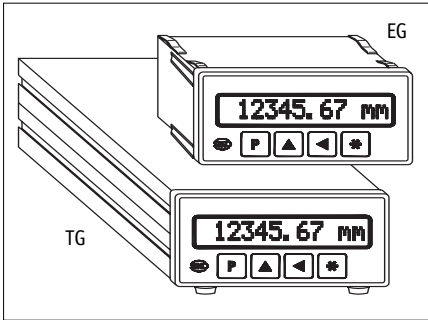

ENGLISH

1. Warranty information

- In order to carry out installation correctly, we strongly recommend this document is read very carefully. This will ensure your own safety and the operating reliability of the device.
- Your device has been quality controlled, tested and is ready for use. Please observe all warnings and information which are marked either directly on the device or specified in this document.
- Warranty can only be claimed for components supplied by SIKO GmbH. If the system is used together with other products, there is no warranty for the complete system.
- Repairs should be carried out only at our works. If any information is missing or unclear, please contact the SIKO sales staff.

2. Identification

Please check the particular type of unit and type number from the identification plate. Type number and the corresponding version are indicated in the delivery documentation.

e.g. MA10/4-0023

_____ version number
 _____ type of unit

3. Summary description

The MA10/4 display is an electronic measurement display. The display is designed to serve different applications depending on its version:

- **Incremental**
 Combined with an incremental encoder the display represents an electronic measuring or display system for distance and angle measurement.

- **SSI**

Combined with an angle encoder (SSI) or another measuring system with SSI interface (e.g., AEA SSI) the display represents an electronic measuring or display system for distance and angle measurement.

- **Rotational speed**

Combined with an electronic or mechanical signal encoder the MA10/4 represents a display system for rotation or speed measurement.

- **Number of pieces (batch)**

Combined with an electronic or mechanical signal encoder the MA10/4 represents a display system for batch measurement.

The MA10/4 can be programmed applicationspecifically. Parameters and displayed value can be stored in the non-volatile memory (EEPROM). The display is also available with an RS232 or RS485 interface or with a switching output.

4. Installation

For mounting, the degree of protection specified must be observed. If necessary, protect the unit against environmental influences such as sprayed water, dust, knocks, extreme temperatures.

Built-in housing EG

- Push the device into the panel (1) until the panel clips (2) hold the housing loosely.
- Press the lateral centering (3) slightly down and push the housing into the cut-out (1) until the panel clips (2) snap completely.

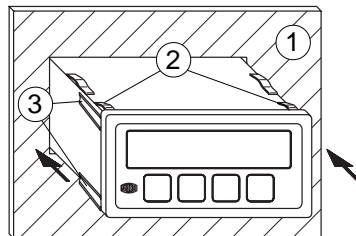

Fig. 1: Installation

Bench housing TG

The rubber feet can be removed in order to screw down the unit.

Attention! Maximum screw insert depth of 6.5 mm must be strictly adhered to!



5. Electrical connection

- **Switch off current before connecting or disconnecting unit!!**
- Any wiring must only be carried out without power.
- Provide stranded wires with ferrules.
- Check all lines and connections before switching on the equipment.

Interference and distortion

All connections are protected against the effects of interference. **The location should be selected to ensure that no capacitive or inductive interferences can affect the display or the connection lines!** Suitable wiring layout and choice of cable can minimise the effects of interference (eg. interference caused by SMPS, motors, cyclic controls and contactors).

Necessary measures:

- Only screened cable should be used. Screen should be connected to earth at both ends. Wire cross section is to be at least 0,14 mm², max. 0,5 mm².
- Wiring to screen and to ground (0V) must be via a good earth point having a large surface area for minimum impedance.
- The unit should be positioned well away from cables with interference; if necessary **a protective screen or metal housing must be provided**. The running of wiring parallel to the mains supply should be avoided.
- Contactor coils must be linked with spark suppression.

Power supply

The L and N terminals serve for voltage supply. Operating voltage depends on execution and is indicated in the delivery documentation or on the identification plate.

e.g. 230 VAC ±10%

Encoder supply

Encoder supply is via terminals 1 (encoder supply +) and 5 (encoder supply -) or 14 (encoder supply +) and 18 (encoder supply -), respectively. The voltage is 24VDC or 5VDC depending on the device version. In both versions maximum current drain of 200mA is possible.

Pin-outs of the encoder signals

The pin-outs of the encoder signals differ depending on the device/ encoder version. Please refer to tables 4 - 7.

Reference/ calibration switch input RFS

The reference point encoder is connected to terminal 7 (RFS) and terminal 9 (GND).

Output of auxiliary voltage

Terminal 6 supplies a voltage of 24VDC/ max.50mA for supplying of proximity switches etc., independent of the way the MA10/4 is supplied.

5.1 Connection of Built-in housing EG

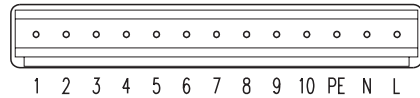

Fig. 2: Pin outs EG (PP-, OC-output circuit, without interfaces and without switching output) for incremental, speed measurement, batch counter

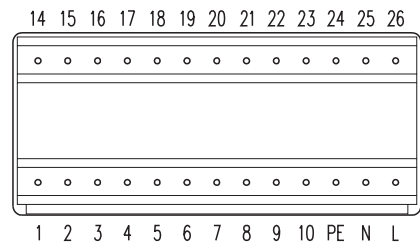

Fig. 3: Pin outs EG for options (LD-output circuit, interfaces, switching output) for incremental, absolute, speed measurement, batch counter

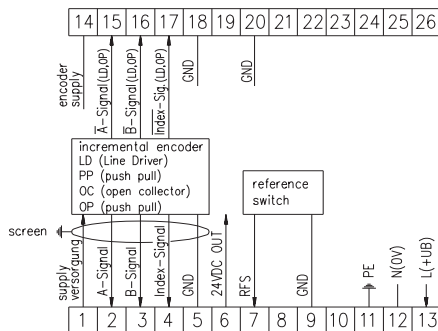

Fig. 4 : Connection diagramm **incremental**

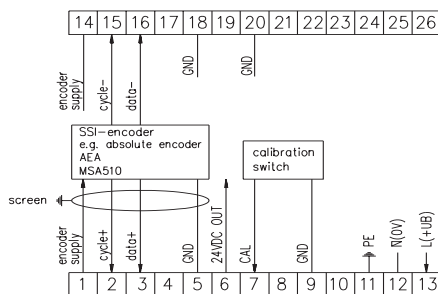

Fig. 5 : Connection diagramm **absolute SSI**

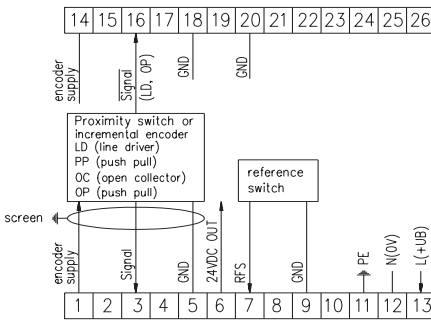

Fig. 6 : Connection diagram **batch counter**

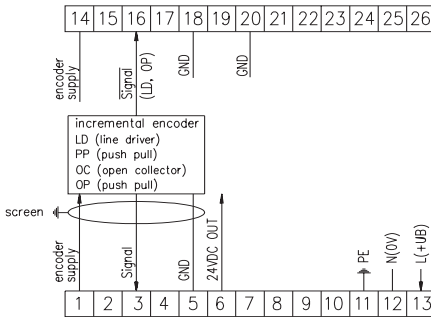

Fig.7 : Connection diagram **speed measurement**

5.1.1 Optional serial RS232 or RS485 interface

The RS232 or RS485 serial interfaces are connected via terminals 20 (GND), 22 (TXD/ DÜA) and 23 (RXD/ DÜB).

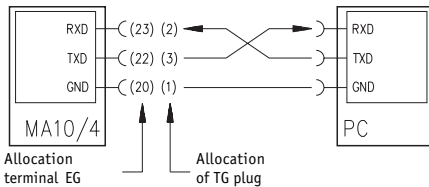

Fig. 8: Connection diagram **RS232 interface option**

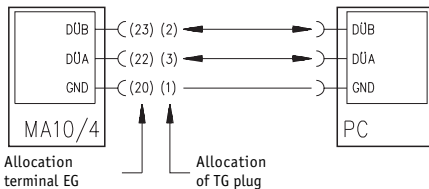

Fig. 9: Connection diagram **RS485 interface option**

5.1.2 Switching output option

Two open collector outputs A1 (terminal 22) and A2 (terminal 23) are available. The common negative pole of these outputs should be connected to terminal 20. The admissible voltage range is 30VDC, the admissible maximum current 10mA per output. The switching behaviour of these outputs is programmable.

- Position value \geq upper limiting value (UPL): actuator 1 active
- Position value \leq lower limiting value (LOL): actuator 2 active

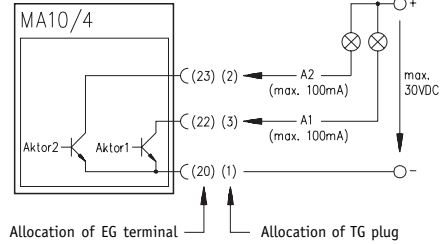

Fig. 10: Connection diagram **switching outputs**

5.2 Connection of bench housing TG

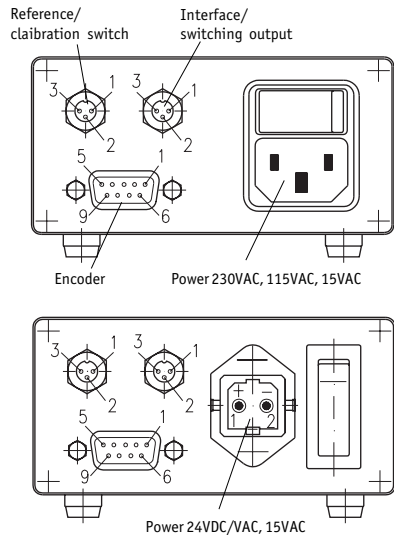

Fig. 8: Pin outs **TG**

5.2.1 Encoder connection (9 pole DSUB socket)

Incremental LD+OP		Absolute SSI	
Pin	Description	Pin	Description
1	+UB	1	+UB
2	A-signal	2	cycle+
3	B-signal	3	data+
4	I-signal	4	N.C.
5	GND	5	GND
6	N.C.	6	N.C.
7	/A-signal	7	cycle-
8	/B-signal	8	data-
9	/I-signal	9	N.C.

Incremental PP+OC		Batch counter/speed measurement	
Pin	Description	Pin	Description
1	+UB	1	+UB
2	A-signal	2	A-signal
3	B-signal	3	N.C.
4	I-signal	4	N.C.
5	GND	5	GND
6-9	N.C.	6-9	N.C.

5.2.2 Reference/Calibration switch connection

via a socket at the rear; pin connections are to be made as follows (fig. 11):

No.	Description
1	RFS / CAL
2	GND
3	+UB

5.2.3 Interface connection

via a socket at the rear; pin connections are to be made as follows (fig. 11):

No.	Description
1	GND
2	RXD / DÜB
3	TXD / DÜA

5.2.4 Option Schaltausgänge

via a socket at the rear; pin connections are to be made as follows (fig. 11). For further information refer to fig. 10, Switching outputs option.

No	Description
1	GND
2	Actuator 2 (A2)
3	Actuator 1 (A1)

6. Commissioning

When the unit's correctly connected and switched on, the display shows for approx. 1,5 sec.:

- hardware version
- firmware version
- type
- address (only with SIKONETZ version)

Subsequently the specific parameters of the machine can be programmed.

Key's function/ Programming mode/ Parameter description/ Input mode etc., see enclosed page with software description.



SIKO GmbH

Dr.-Ing. G. Wandres

Werk / Factory:

Weihermattenweg 2
79256 Buchenbach-Unteribental

Postanschrift / Postal address:

Postfach 1106
79195 Kirchzarten

Telefon/Phone +49 7661 394-0

Telefax/Fax +49 7661 394-388

E-Mail info@siko.de

Internet www.siko.de