



MAGLINE^{MICRO}
MAGLINE^{BASIC}
MAGLINE^{MACRO}
MAGLINE^{ROTO}

Magnetic Length Measuring System...
...lengths ahead!



MAGLINE^{MICRO}

Especially suitable for precise and highly dynamic processes on linear guide systems and applications in the field of motive power engineering, MAGLINE^{MICRO} is a magnetically sensing incremental system with programmable resolutions up to 0.2 μm and a measuring accuracy of max. 10 μm . MAGLINE^{MICRO} system operates without wear, with measuring values captured contactlessly. This makes the system a robust and economic alternative to optical measuring systems.

μm

MAGLINE^{BASIC}

This system combines all advantages of the contactless magnetic measuring technology and offers resolutions up to 1 μm and a measuring accuracy of max. 50 μm . MAGLINE^{BASIC} is available as both an incremental or absolute measuring system. MAGLINE^{BASIC} either provides digital encoder signals or directly displays the values measured at the position the sensor is placed.

MAGLINE^{MACRO}

Especially designed for very long measuring lengths. A system for measuring lengths of 100 meters and more -incrementally or absolutely. Digital signal outputs allow data transmission of the measured values with a resolution of up to 0.25 mm to a display unit or a master control.

MAGLINE^{ROTO}

Primarily developed for direct angle and rotation recording with all the advantages of magnetic, contactless sensing. Appropriate sensors register the incremental segmentation of magnet rings at revolutions of up to 6,000 rpm and a maximum resolution of 200,000 steps per revolution.

Contents

Magnetic length measuring system MAGLINE^{MICRO}



4	MAGLINE ^{MICRO} – the product and its applications
5	Use at customer. The technically feasible!
6	The system and its components
7	Magnetic band MB100
8	Magnetic sensor MS100/1
9	Magnetic display MA100/2
10	Magnetic sensor MSK1000
11	Linear Encoder LE100/1
12	Linear Encoder LS100
14	Appendix: Accuracy data/ Signal illustration
15	Appendix: Pin outs

MAGLINE^{MICRO} Safe Sensing Security

The magnetic linear system: Insensitive to contamination.
within Micrometer Range!

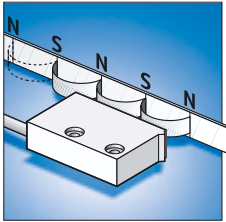

MAGLINE^{MICRO} senses magnetic fields contactlessly and transforms the measured values into digital or analog signals.

Many technical applications require capturing travel, rotary angle or positioning moves. Environmental conditions are often extreme, for example in the work-room of a machining center. Highest precision is demanded despite unfavorable environmental influences and high travel speeds. Values measured are directly shown on a display or transmitted as input signal to the machine's control.

The MAGLINE^{MICRO}-system fulfills these requirements effortlessly since it detects the movement contactlessly on a magnetic scale with

a technology that surpasses the sensing reliability of most optical processes.

The scale is fabricated of specially developed magnetic materials depending on the necessary accuracy. As the sensor travels along the magnetic band contactlessly, the system works without wear and is completely insensitive to contamination such as dust or liquids. Measured data can either be displayed directly where the system is mounted or transmitted to an electronic control. Measured data is transformed into distance/direction information.

Easy handling and mounting makes the MAGLINE^{MICRO} system perfectly suitable for retrofitting to existing machines.

At a maximum measuring length of four meters MAGLINE^{MICRO} achieves a resolution of 0.2 μm . Repeat accuracy is 1 μm , with an absolute accuracy of up to 10 μm . All important parameters are individually programmable allowing an adaptation of the system to the application's requirements. The system either issues digital square or analog signals.

MAGLINE^{MICRO} system is an economical alternative to conventional length measuring systems. Robust components and the insensitive measuring principle make this system suitable for a multitude of applications.

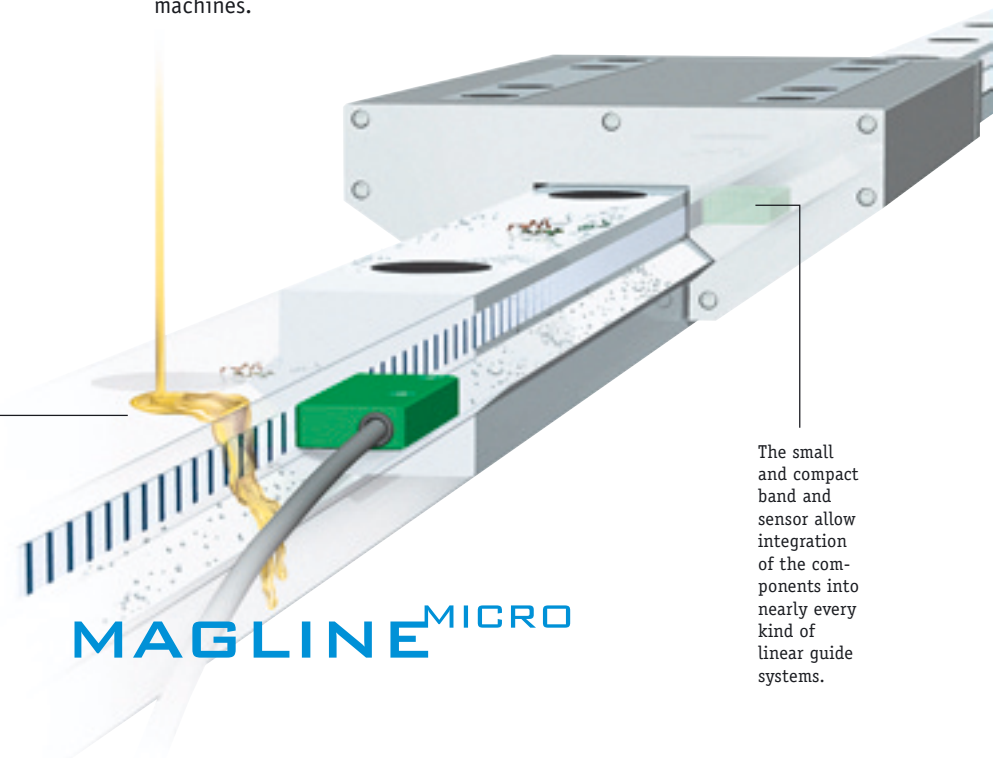

Even when the magnetic band is completely covered with oil or grease, the length information will be correctly captured and recorded.

The small and compact band and sensor allow integration of the components into nearly every kind of linear guide systems.

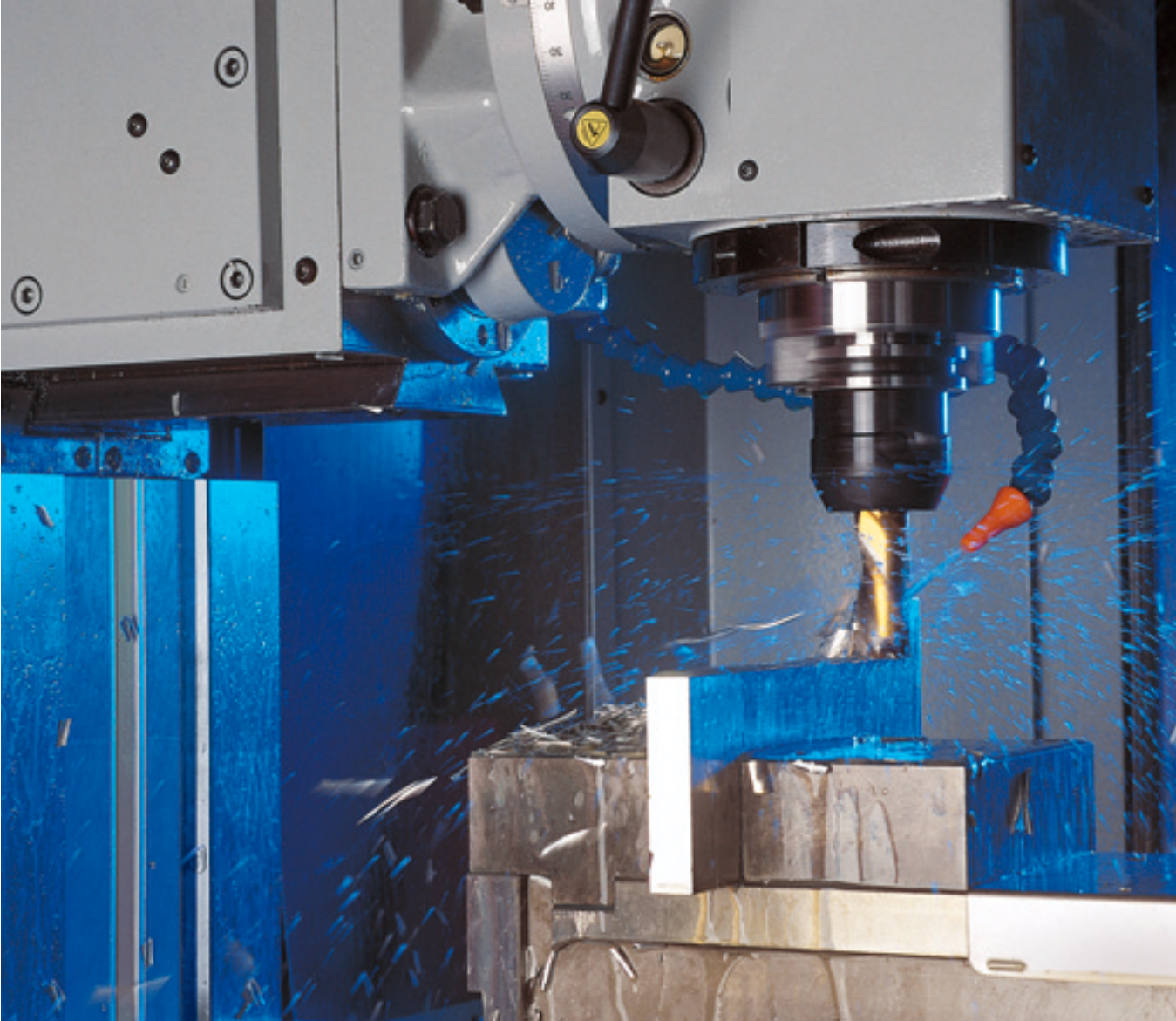

At the Customer

The technically feasible!

Repeatedly measure, test, adjust: Precision tools in the proven SIKO design guaranteed by quality assurance for a multitude of user groups.



MAGLINE^{MICRO} is a length measuring system for micrometer range use, suitable for various applications and a perfect solution for linear guide and motive power engineering systems. As the magnetic band can be bent to a radius, MAGLINE^{MICRO} may also be used for angle measurement applications with large angle resolution such as circular tables. Direct or close mounting to the place of

positioning/processing helps to prevent incorrect measuring values which might result from gear backlash or spindle tolerances. Thanks to its solid design, additional protection of the measuring system is not necessary. That makes mounting easy and saves costs.

Product Survey

MAGLINE^{MICRO} and its components

Series 100

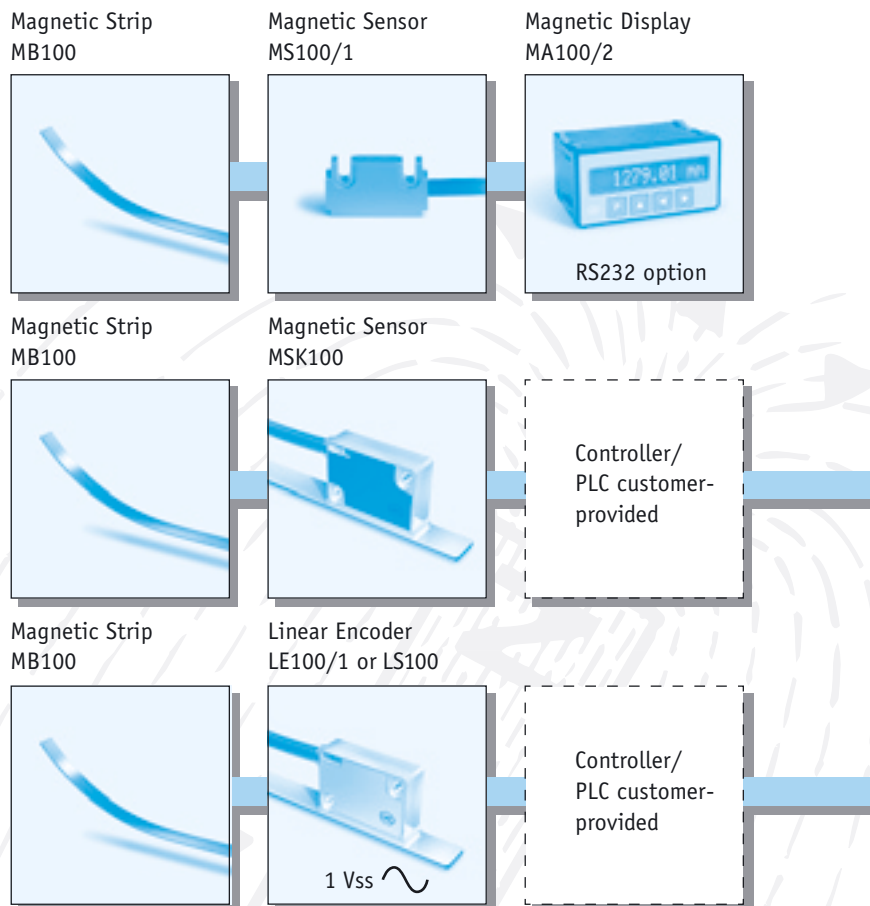

Magnetic Strip MB100

The magnetic band consists of a magnetic tape magnetized at regular distances and firmly joined with the carrier strip. For mounting a special adhesive tape is pre-mounted.

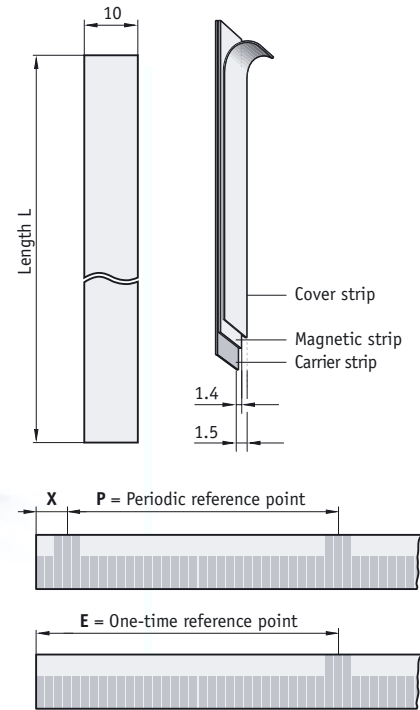

Features:

- easy mounting by glueing
- insensitive to dust, shavings, humidity ...

Attention! In case of danger of corrosion (e.g., salt-water or similar environments), VA carrier strip available as an option. When using cooling lubricants or similar substances please take notice of the specific mounting instructions (on request)

Reference points, all in m

X	P	E
0.02	0.02/ 0.06/ 0.1/ 0.14	0.02/ 0.08/ 0.14/ 0.2
	0.18/ 0.22/ 0.26/ 0.34	0.26/ 0.32/ 0.38/ 0.44
	0.42/ 0.5	0.5

other reference points on request

Feature	Ordering data	Technical data	Additional information
Length	...	length in meter, available in steps of 100 mm	ordering length = required length + 30 mm
Width	10 5	10 mm 5 mm	standard
Precision class	0.01 0.05	10 µm, ordering length 4000 mm 50 µm, max. ordering length 90000 mm	standard
Carrier material	St VA	spring steel strip stainless steel strip	standard
Adhesive carrier band	TM TO	with without	standard
Cover strip	AM AO	with without	standard
Reference point	0 E P	without one time periodic	standard only for 10 mm width only for 10 mm width
Position of E reference point (ohne-time)	0.02	in m	standard, see drawing
or			
Position of P reference point (periodic)	0.02	in m	standard, see drawing
Temperature coefficient		$(11 \pm 1) \times 10^{-6} / K$	
Temperature ranges		working temperature: -20 ... +70 °C	storage temperature: -40 ... +70 °C
Type of protection		IP67 according to DIN VDE 0470	
Mounting type		glued joint	pre-mounted special adhesive tape

Your order:

MB100 - - - - - - - - -

Magnetic Sensor MS100/1

The information of the magnetic strip MB100 is captured contactlessly. The sensor with the permanently connected cable passes the information on to a magnetic display or a follower electronics unit.

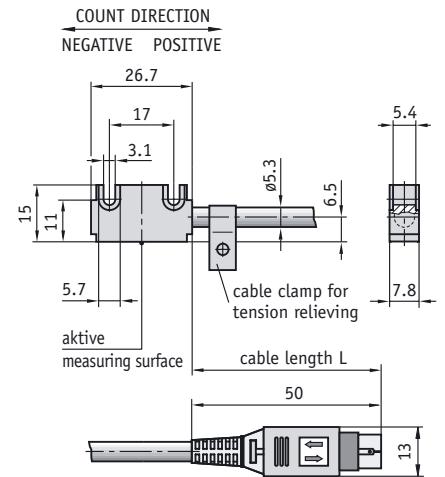
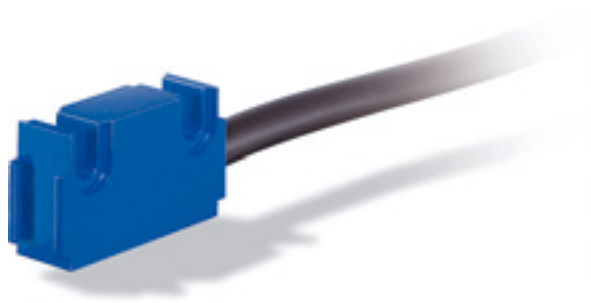

Features:

- small, compact size
- solid casing
- insensitive to mechanical influences
- **Attention!** No modification of the sensor connection is permitted (e.g. other cable/ cable length/...)

Feature	Ordering data	Technical data	Additional information
Design	L A	type L, aluminium anodized, blue color	standard
Cable length	1.0 B	in meter, in steps of 1.0 m	standard (available up to 10 m)
Cable sheath	PVC C PUR	oil-resistant	standard
Mounting position		arbitrary	
Connection		Mini-DIN	for magnetic display MA100/2
Gap strip/ sensor		0.1 – 0.4 mm	over whole measuring range, without cover strip
Travel speed		max. 5 m/s	
Temperature ranges		working temperature: -20 ... +70 °C	storage temperature: -20 ... +85 °C
Humidity		100 % rH	condensation permitted
Protection class		IP 67 according to DIN VDE 0470	
Mounting type		by means of screws	

Your order:

MS100/1 - - -

Magnetic Display MA100/2

This display interprets the data of distance and angle measurement captured by the magnetic sensor MS100/1. The display is widely and individually programmable and is also available with integrated power pack and bench-top housing.



Features:

- high-contrast 12-digit LCD, dot matrix
- integrated translation module for length and angle measurement
- Resolution max. 1 μm , precision class 10 μm
- incremental/ reset function
- input for reference switch
- direct input of reference/ offset value
- serial RS232/ RS485 interface as an option

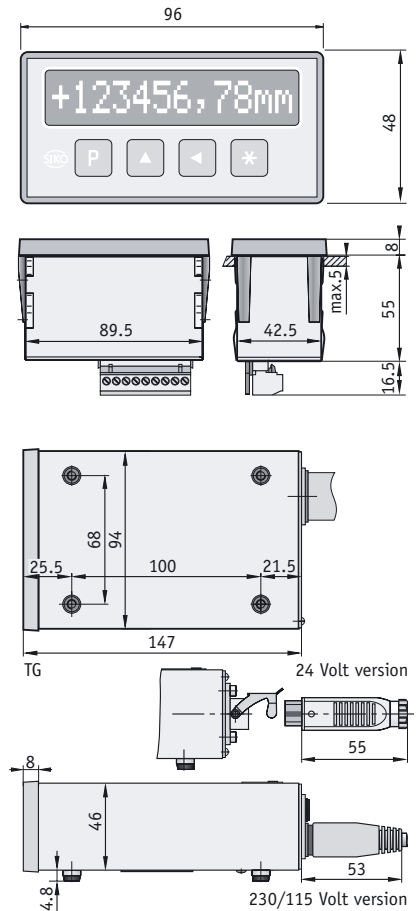

Feature	Ordering data	Technical data	Additional information
Design	EG	panel-mount housing, cutout 92 x 45 mm	standard, Noryl GFN 2 SE 1, as snap-in module
	TG	bench top housing	aluminium profile, black anodized
Operating voltage	4	24 V DC $\pm 20\%$	standard
	1	230 V AC $\pm 10\%$	
	2	115 V AC $\pm 10\%$	
Reference connection	RM	with connection	standard
	RO	without (only bench-top housing)	
Interface/ protocol	XX/XX	without	standard
	S1/00	RS232 with standard protocol	
	S3/00	RS485 with standard protocol	
Switching output	S0	without	standard
	SM	with	only for XX/XX interface
Display/ display range		12-digit LCD dot matrix	-9 999 999 ... 9 999 999 + sign + units
Connection		sensor pluggable: Mini-DIN	supply: 9-pin screwed terminal strip (EG)
Travel speed		max. 5 m/s (of the magnetic sensor)	with 0.1 – 0.4 mm strip/ sensor gap
Resolution		in mm 0.001/ 0.01/ 0.1/ 1/ 10	in inch 0.001/ 0.01/ 0.1/ 1
Repeat accuracy		± 1 digit	
System accuracy		$\pm(0.01 + 0.01 \times L)$ mm [L in m]	at $T_u = 20^\circ\text{C}$; for magnetic strip type MB100 (10 μm precision)
Protection class/ Test mark		3, according to IEC 801	CE
Signal input		reference switch	
Temperature ranges		working temperature: 0 ... $+50^\circ\text{C}$	storage temperature: $-20 \dots +80^\circ\text{C}$
Type of protection		IP 40 acc. to DIN 40050 for whole unit	IP 60 acc. to DIN 40050 for control panel inclusion
Humidity		95% rH	condensation not permitted

Your order:

MA100/2 - - - - -

Magnetic Sensor MSK1000

Contactless measuring sensor unit with integrated translation module and digital signal output. In combination with the magnetic band MB100, the sensor forms an open, robust and linear measuring system with high resolution at a reading distance of 0,4mm.

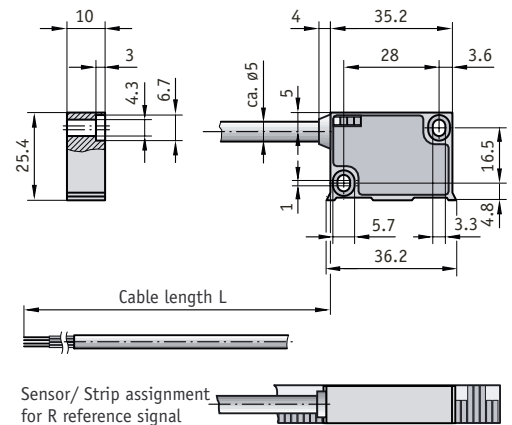

Features:

- Resolution up to 0,2µm
- free programmable parameters (e.g. resolution) via optical interface
- Status LEDs
- real-time data processing
- fix and periodical reference signals
- robust metal housing

Resolution [mm]	travel speed Vmax. [m/s]			
0.0002	0.64	0.32	0.16	0.08
0.001	3.20	1.60	0.80	0.40
0.002	6.40	3.20	1.60	0.80
0.005	16.00	8.00	4.00	2.00
Puls interval [µs]	0.25	0.50	1.00	2.00
Counter frequenz [kHz]	1000.00	500.00	250.00	125.00

Feature	Ordering data	Technical data	Additional information
Operating voltage	10 11	6,5 - 30 V DC 4,75 - 6 V DC	standard, with polarity protection
Type of connection/cable length	E1/1.0 .../...	stripped lead, 1 m cable E6, circular plug	standard (max. 20 m cable length) E8, D-SUB 9-pin
Reference signal	0 I RB	without index periodic reference point fixed	standard on tape side
Resolution	1 D	1 µm	standard , option 0.02/2/5
Pulse interval	1 E	1 µs	standard , option 0.25/0.5/2
Power consumption		<25 mA	unloaded
Output circuit		LD	line driver
Output signals		A, /A, B, /B, option: I, /I or R, /R	quadrature signal
LED status signals		A, B, I or R, power	
Gap sensor / magnetic strip		0.1-0.4 mm, reference signal R 0.1-0.2 mm	lateral offset ± 1 mm, with reference signal R ± 0.5 mm
System accuracy		±10 µm	repeat accuracy ±5 µm, with T _U = 20 °C
Velocity		max. 16 m/s	depending on resolution and pulse interval
Temperature ranges		operating temperature: -10 ... +70 °C	storage temperature: -30 ... +80 °C
Interference protection class		3, according to IEC 61000-6-2	humidity: 100 % rF, condensation permitted contact surface
Type of protection		IP67 acc. to DIN 40050 (housing)	test mark CE
Housing		diecast	lateral cover aluminium
Cable		PUR, dragchain capable	

Note: The internal translation module can generate fast counting pulses, the lengths of which are limited by the pulse interval. The follower electronics must be adjusted accordingly. Select the pulse interval in advance, if necessary.

Your order: - - - - -

Linear Encoder LE100/1

Contactlessly measuring scanning unit with integrated analog signal output (sine 1 V_{ss}). Together with the magnetic scale MB100 and a follower interpolation electronics unit, the LE100/1 forms an open linear measuring system.



Features:

- easy mounting
- LED status display
- signal period 1000 µm (analog)
- scale MB100
- reference signal (option)
- insensitive to dust, shavings, humidity

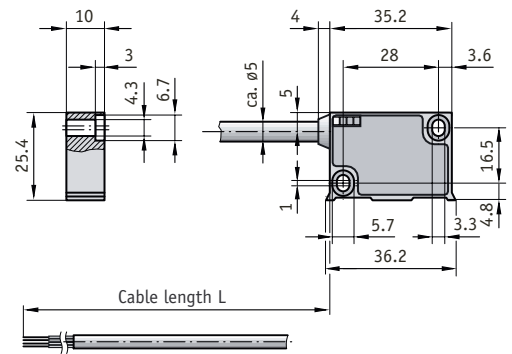

Sensor/ Strip assignment for R reference signal

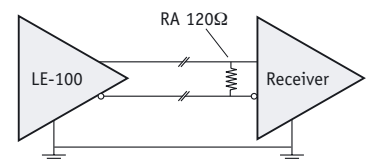

Feature	Ordering data	Technical data	Additional information
Operating voltage	4	24 V DC ±20%	standard, with polarity protection
	5	5 V DC ±5%	
Connection	E1/1.0	flying leads/ 1 m cable	standard, max. 10 m
	E6/...	circular plug	
Reference signal	0	without	standard
	I	analog, period. index signal every 1 mm	RS422 (Line Driver)
	RB	fix reference signal analog, on tape side	see signals illustration in the appendix
Power consumption		<25mA @24VDC; <50mA @5VDC	with polarity protection at operating voltage 24 V DC
Output signals		Sin, Cos, /Sin, /Cos, I, /I, or R, /R	
Signal amplitude		1 V _{ss} ±10 % @0 - 70 °C	with RA = 120 Ohm up to 1 kOhm
Output impedance		0 Ohm (Rload > 75 Ohm)	short-circuit-resistant
Sine/ Cosine offset		2.5 V ±0.5 %	
Phase position sine/cosine		90° ±1°; <±3° (20kHz)	
Phase position of reference signal		Sin 45°; Cos 135°	
Pulse width of reference signal		±75° (±5°)	
Real time requirements		real-time signal processing	
Signal period		1000 µm	
Travel speed		max. 20 m/s	with RB: 5 m/s
System accuracy		max. 1 % related to dividing period	
Harmonic distortion		< 1%	
Gap strip/ sensor		0.1 - 0.4 mm, reference signal RB < 0.2 mm	over whole measuring distance, without cover strip
Parallel sensor/ strip offset		±0.5 mm	angle offset ±3° (±1° with RB)
Temperature range		working temperature: -10 ... +70 °C	storage temperature: -30 ... +80 °C
Interference protection class		3, according to IEC 801	Humidity max. 95%rF
Protection class		IP 67, according to DIN VDE 0470	test mark CE
Vibration resistance		<200m/s ² (50Hz ... 2000Hz)	
Shock resistance		<300m/s ² (11ms)	
Housing		diecast	lateral cover aluminium
Cable		PUR, dragchain capable	

Your order: LE100/1 - - -

Linear Encoder LS100

Contactlessly measuring scanning unit with integrated analog signal output (sine 1 V_{ss}). Together with the magnetic scale MB100 and a follower interpolation electronics unit, the LS100 forms an open linear measuring system.

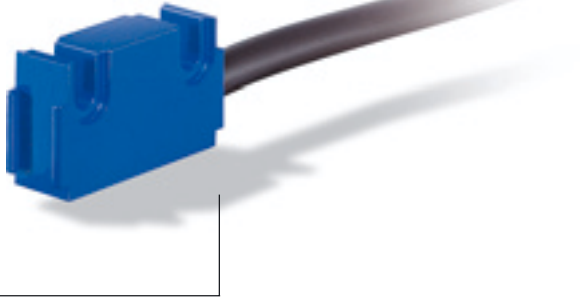

Features:

- easy mounting
- insensitive to dust, shavings, humidity
- signal period 1000 µm (analog)
- output signals 1 V_{ss} nominal
- real-time data processing

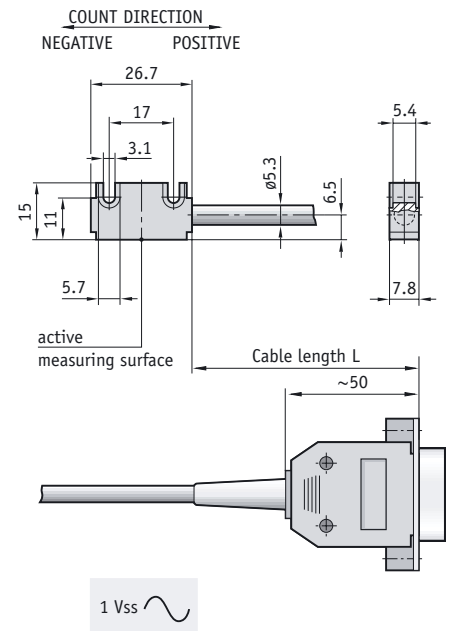

Feature	Ordering data	Technical data	Additional information
Operating voltage	4	24 V DC ±20 %	standard
	5	5 V DC ±5 %	
Connection	L	cable length L in meter	L=cable length in meter, available up to 10 m; standard 2.0 m 15-pin D-SUB connector
	B		
Cable length	PVC	oil-resistant	standard
	PUR		
Power consumption		approx. 30 mA unloaded	with polarity protection at operating voltage 24 V DC
Output signals		Sin, Cos, /Sin, /Cos	
Signal amplitude		1 V _{ss} ±10 %	with resistor R=120 Ω bis R=1 kΩ
Sine/ Cosine offset		2.5 V ±0.5 %	
Counting frequency		50 kHz	
Real time requirements		real-time signal processing	
Signal period		1000 µm	
Travel speed		max. 20 m/s	
System accuracy		max. 1 % related to dividing period	
Gap strip/ sensor		max. 0.4 mm	over whole measuring distance, without cover strip
Sensor temperature ranges		working temperature: -20 ... +70 °C	storage temperature: -20 ... +85 °C
Plug temperature ranges		working temperature: 0 ... +60 °C	
Interference protection class		3, according to IEC 801	test mark CE
Protection class		IP 67	according to DIN VDE 0470
Vibration resistance		[5... 2000 Hz] at 20 g	
Shock resistance		200 g at 11 ms	
Material of casing		aluminium, blue varnish	

Your order:

LS100 - - -

Appendix: Accuracy data, Signals illustration

Typical Measuring Curves

Magnetic strip MB100, sensor system MA100/2 with MS100, width of measuring steps 1.1 mm

A Accuracy class: 10 μm

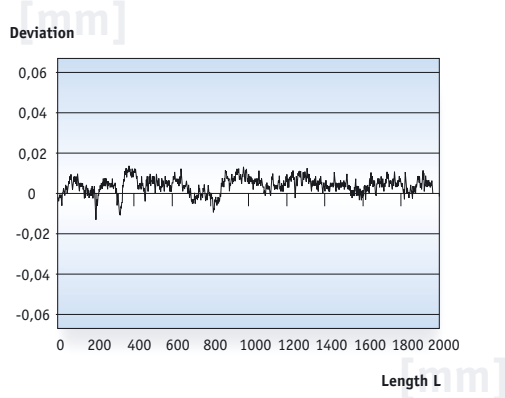

B Accuracy class: 50 μm

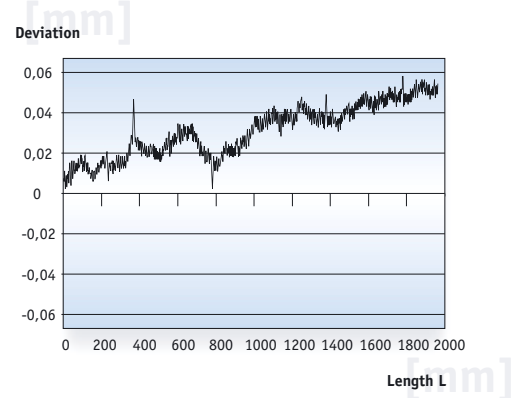

Signals LE100/1

Note: Signal illustration refers to difference measurement

- E: 0 V ±5 mV (reference voltage 2.5 V)
- F: 1 V_{ss} ±10 %
- Relation of G to H: Offset ±10 mV
- J: ≥ 0.2 V
- K: 0.7 V ±10 %
- L: 60° ... 80°
- M: 90° ±1.5° / <±3° (20 kHz)

with index and reference signals

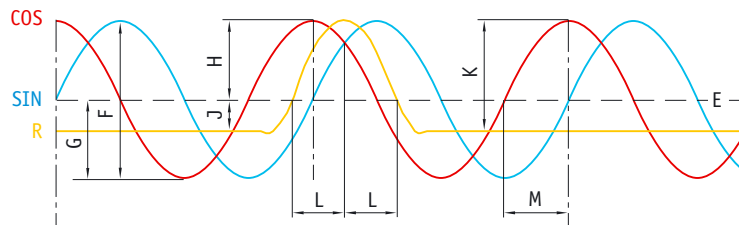

Signals MSK1000

Note: With the MSK1000, the position of the index signal I/R with regard to signals A and B is not defined. The index signal length is 1 increment with the MSK1000.

with index, reference signals and inverted signals

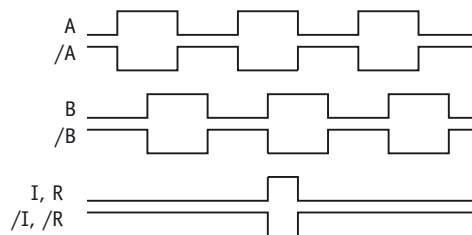

Pulse interval MSK1000

The pulse distance "t" is the shortest time period which can occur between two signal edges when moving the magnetic sensor. Micro vibration can trigger it for example. It must be made sure that the follower electronics is able to correctly process the signals.

Pulse interval

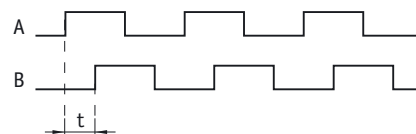

Example: pulse interval $t = 1 \mu\text{s}$

$$\text{input frequency} = \frac{1}{1 \mu\text{s} \cdot 4} = 250 \text{ kHz}$$

The follower electronics must be able to work with 250 kHz.

Appendix: Pin outs

MA100/2
Panel snap casing
(EG)

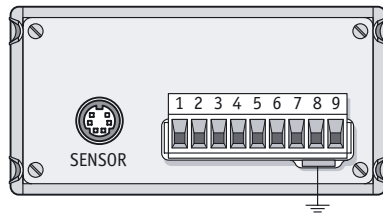

PIN	Terminal strip connections
1	RESET
2	+UB
3	GND
4	N.C.
5	Interface RS232 RXD
6	Interface RS232 TXD
7	PE
8	N (230/110 V AC), GND (24 V DC)
9	L (230/110 V AC), UB (24 V DC)

MA100/2
Bench top casing (TG)
230 V / 115 V

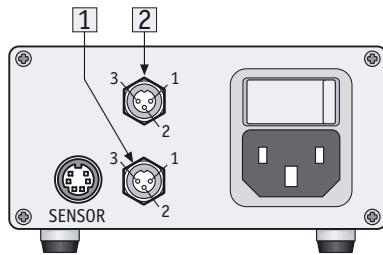

1	PIN	Reference switch connections
1	1	RFS
2	2	GND
3	3	+UB

2	PIN	Interface connections	Switching output
1	1	GND	GND
02	02	RXD	A2
03	03	TXD	A1

MA100/2
Bench top casing (TG)
24 V

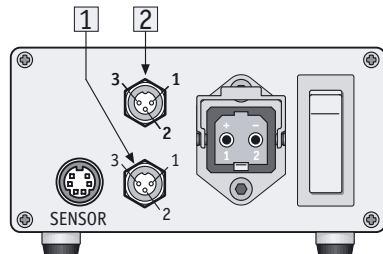

1	PIN	Reference switch connections
1	1	RFS
2	2	GND
3	3	+UB

2	PIN	Interface connections	Switching output
1	1	GND	GND
02	02	RXD	A2
03	03	TXD	A1

**LE100/1 and
MSK1000**
Connection E1/L

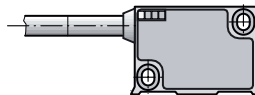

LE100/1	Color	Connection
	black	GND
	red	sin
	blue	idx
	orange	/sin
	yellow	cos
	green	/cos
	brown	+UB
	purple	/idx

MSK1000	Color	Connection
	black	GND
	red	A
	blue	I, R
	yellow	/A
	orange	B
	green	/B
	brown	+UB
	purple	/I, /R

LS100

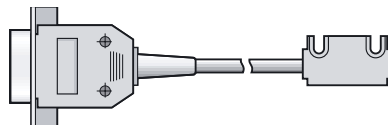

PIN	Connection
2	GND (0V)
5	/B (COS-)
6	B (COS+)
7	A (SIN+)
8	/A (SIN-)
10	GND (0V)
12	+UB
14	GND (0V)
1,3,4,9,	N.C.
11,13,15	N.C.

Faxa Inquiry

for immediate information

+ 49 (0) 76 61 / 3 94 - 388

To receive more information, simply mark the appropriate item(s) in the list below and fax this page to us. We will gladly inform and advise you.

- Technical advice on the integration of MAGLINE products
- Visit of a SIKO sales representative
- Pricelist for SIKO products/MAGLINE
- Product catalogue on CD-ROM
- All brochures "MAGLINE" to the following address
- Catalogue with brochures on the complete SIKO product range

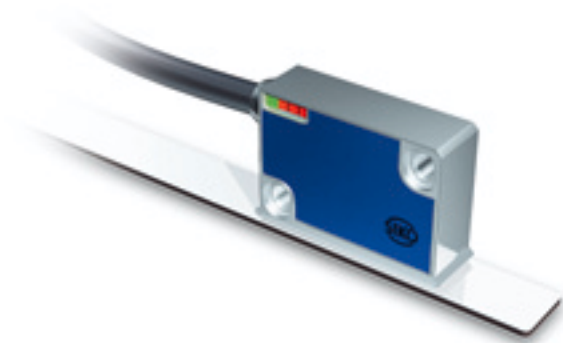

From:

Name

Company

Department/Function

Street

Zip code/City

Phone

Fax

e-mail

Company stamp



SIKO GmbH
Weihermattenweg 2
79256 Buchenbach
Germany

Telephone
+49 7661 394-0
Telefax
+49 7661 394-388

eMail
info@siko.de
Internet
www.siko.de

Looking for a dealer near
to you?

You can find the complete
addresses of all SIKO product
representatives in the support
section of our website:

www.siko.de

SIKO Products Inc.
P.O. Box 279
Dexter, MI 48130
USA

Telephone
+1 734 42 63 476
Telefax
+1 734 42 63 453

eMail
sales@sikoproducts.com
Internet
www.sikoproducts.com

SIKO Ltd.
Unit 6, Dalton Lane
Codbeck Estate, Dalton
Thirsk, North Yorkshire
YO7 3HR
United Kingdom

Telephone
+44 1845 578845
Telefax
+44 1845 577781

eMail
sales@siko-uk.com
Internet
www.siko-uk.com

SIKO Italia S.r.l.
Via Borromeo, 4
I-20017 Rho MI
Italy

Telephone
+39 02 93 90 63 29
Telefax
+39 02 93 46 95 32

eMail
info@siko-italia.com
Internet
www.siko-italia.com

**SIKO Mess- und
Positioniersysteme
GmbH**
Deisrütistrasse 11
8472 Seuzach
Switzerland

Telephone
+41 52 317 46 41
Telefax
+41 52 317 46 42

eMail
info@siko-schweiz.ch
Internet
www.siko-schweiz.ch

**SIKO International
Trading (Shanghai)
Co. Ltd.**
Unit A, 26th Floor New
Rainbow Jie Yun Bldg.,
2 Lane 600, Tian Shan
Road, Shanghai/
China 200051

Telephone
+86 21 62 59 47 45
Telefax
+86 21 32 11 04 20

eMail
info@siko.cn
Internet
www.siko.cn