

Magnetic sensor MSK320

As a component of a magnetically operating, open and robust measuring system, this sensor has integrated interpreting electronics and a direct, digital signal output. Used in conjunction with the magnetic rings MR320/MRI01 the sensor forms an open and robust rotary encoder system.

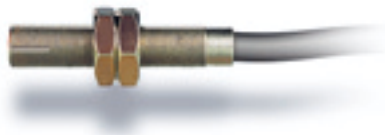

Features:

- insensitive to dust, shavings, humidity
- max. resolution 0.018°, system accuracy $\pm 0.1^\circ$
- real-time data processing
- rotary encoder system with IP67 protection class (MR320/MRI01)
- fixed index signals

Note: For supply voltage 4, output circuit LD and reference signal I/R it is necessary to use a terminating resistor of $\geq 470 \text{ Ohm}$ to prevent thermal stress.

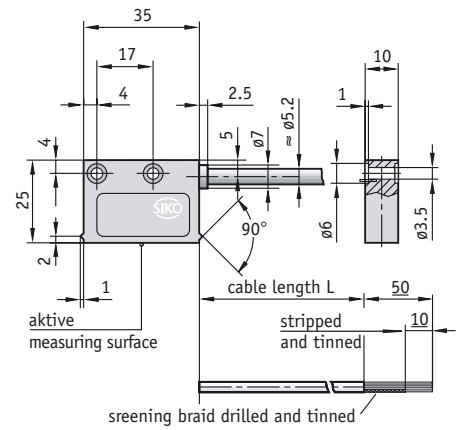

Array sensor / ring for reference signal R

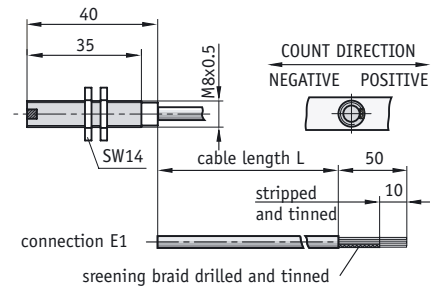

Feature	Ordering data	Technical data	Additional information
Supply voltage	4 5	24 V DC $\pm 20\%$ 5 V DC $\pm 5\%$	standard, with polarity protection
Design	A F	rectangle circular design	standard
Connection / cable length	E1/2.0 E6, E8	2 m cable, flying leads E6, circular plug	standard (cable length max. 20 m) E8, DSUB 9 pins
Output circuit	PP LD TTL	push pull line driver	standard only with non-inverted output signal (cable length max. 5 m)
Output signal	NI I	not inverted inverted	standard
Reference signal	0 I R	without index periodical index fixed	standard
Scaling factor	8	factor 8	standard, option 20 / 16 / 10 / 5 / 4 / 1 for design F only scaling factor 8 / 4 possible
Power consumption		max. 70 mA	@ 24 V DC unloaded
Output signals		A,B A, /A, B, /B, option: I, /I, or R, /R	quadrature signal only design A, quadrature signal
Gap ring/ sensor		0.1 – 2.0 mm, Reference signal R < 1.5 mm	lateral offset $\pm 1 \text{ mm}$, angular offset $\pm 3^\circ$
System accuracy		$\pm 0.1^\circ$	repeat accuracy ± 1 increment
Jitter		< 15%	for sensor / ring gap 0,5 mm
Travel speed		max. 25 m/s	max. reference speed 3.2 m/s
Interference protection class		3, acc. to IEC 801	humidity: 100 % rF, condensation permissible
Temperature ranges		working temperature: $-10^\circ \dots +70^\circ \text{C}$	storage temperature: $-30 \dots +80^\circ \text{C}$
Protection class		IP67 acc. to DIN 40050 (casing)	test mark: CE
Housing		rectangular housing, plastic red	circular housing, steel
Cable		PUR	

Your ordering data: MSK320 - [A] - [B] - [C] - [D] - [E] - [F] - [G]

Magnetic ring MRI01

On this ring, the carrier material for the coding is attached and magnetized in defined intervals. The magnetic ring is used as a scale and together with the MSK320 sensor unit it forms a robust measuring system for angle and rotation measurement.

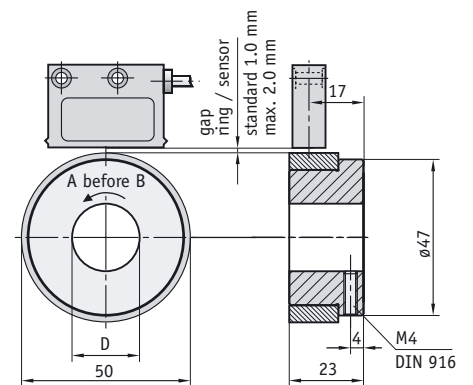

Features:

- easy mounting due to hollow shaft
- insensitive to dust, shavings, humidity, liquids, and oils
- rotary encoder system with IP67 protection class (in combination with MSK320)
- up to 1280 pulses/turn : 5120 increments after 4x pulse multiplication

Feature	Ordering data	Technical data	Additional information
Pole pitch	64 A	64 poles distrib. over the circumference	Standard $\varnothing 50 / U = 0.157$ m
Bore D ^{H8}	20 B 9	inside diameter 20 ^{H8} inside diameter 9 ^{H8}	Standard others on request
Impulse/turn		see appendix	
Gap sensor / magnetic ring		see drawing	
System accuracy		$\pm 0.5^\circ$	
Material		aluminium	
Working temperature		0 ... + 60 °C	
Storage temperature		-20 ... + 85 °C	
Humidity		100% rF, condensation permitted	
Max. rotational speed		calculation: see appendix	

Your ordering data: MRI01 - -

Magnetic ring MR320

On this ring, the carrier material for the coding is attached and magnetized in defined intervals. The magnetic ring is used as a scale and together with the MSK320 sensor unit it forms a robust measuring system for angle and rotation measurement.



Features:

- easy mounting due to hollow shaft
- insensitive to dust, shavings, humidity, liquids, and oils
- rotary encoder system with IP67 protection class (in combination with MSK320)
- up to 5000 pulses/turn : 20000 increments after 4x pulse multiplication
- index signal

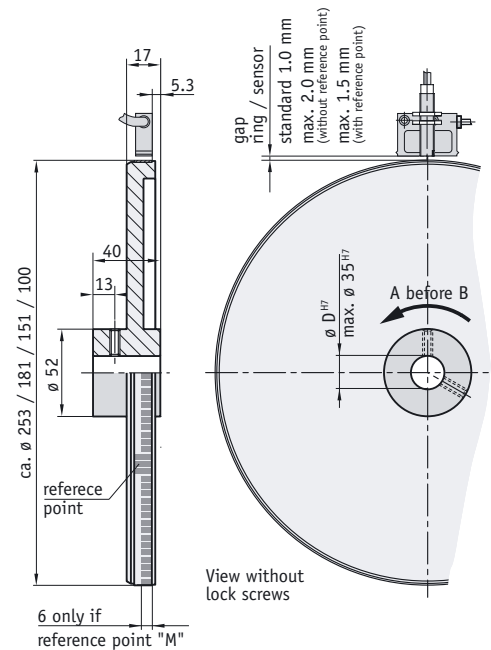

Feature	Ordering data	Technical data	Additional information
Pole pitch	150	A	150 poles, distrib. over the circumference
	100		100 poles, distrib. over the circumference
	160		160 poles, distrib. over the circumference
	250		250 poles, distrib. over the circumference
Bore D ^{H7}	20	B	20 H7
			standard (max. 20 H7), other on request
Mounting mode	MNG	C	hub thread
			standard
Referenzpunkt	0	D	without
	M		with
			standard
Impulse/turn			see appendix
Gap sensor / magnetic ring			see drawing
System accuracy			± 0.1 °
Material			aluminium
Working temperature			0 ... + 60 °C
Storage temperature			-20 ... + 70 °C
Humidity			100 % rF, condensation permissible
Max. rotational speed			calculation: see appendix

Your ordering: MR320 - - - -

Appendix: Output circuits, Signal illustration

MSK210/MSK320 version A

Output signal A / B
Output circuit TTL

Power supply	Output driver	U_{HIGH} (unloaded)	U_{LOW} (unloaded)	$I_{max}/channel$
24 V	AM26C31	> 4.5 V	< 0.15 V	5 mA
5 V	AM26C31	> 4.5 V	< 0.15 V	5 mA

Output signal A / B and I inverted
Output circuit PP

Power supply	Output driver	U_{HIGH} (unloaded)	U_{LOW} (unloaded)	$I_{max}/channel$
24 V	OL7272	> $U_B - 0.8$ V	< 0.5 V	50 mA

Output signal A / B and I inverted
Output circuit LD; 120 ohm connection

Power supply	Output driver	U_{HIGH} (unloaded)	U_{LOW} (unloaded)	$I_{max}/channel$
24 V	AM26C31	RS422 spec.	RS422 spec.	$R_{last} > 470$ Ohm
5 V	AM26C31	RS422 spec.	RS422 spec.	RS422 spec.

MSK320 version F

Output signal A / B
Output circuit PP not short-circuit proof

Power supply	Output driver	U_{HIGH} (unloaded)	U_{LOW} (unloaded)	$I_{max}/channel$
24 V	transistor	> $U_B - 1$ V	< 0.15 V	50 mA

Output signal A / B
Output circuit TTL

Power supply	Output driver	U_{HIGH} (unloaded)	U_{LOW} (unloaded)	$I_{max}/channel$
24 V	74HC04	> 4.5 V	< 0.15 V	5 mA
5 V	74HC04	> 4.5 V	< 0.15 V	5 mA

MSK500/1

Output signal A / B and I inverted
Output circuit PP

Power supply	Output driver	U_{HIGH} (unloaded)	U_{LOW} (unloaded)	$I_{max}/channel$
24 V	OL7272	> $U_B - 0.8$ V	< 0.5 V	50 mA

Output signal A / B and I inverted
Output circuit LD; 120 ohm connection

Power supply	Output driver	U_{HIGH} (unloaded)	U_{LOW} (unloaded)	$I_{max}/channel$
24 V	AM26C31	RS422 spec.	RS422 spec.	$R_{last} > 470$ Ohm
5 V	AM26C31	RS422 spec.	RS422 spec.	RS422 spec.

Signal illustration

Note: position of the index signals I/R in regards to signals A and B is not defined with sensor MSK500/1.

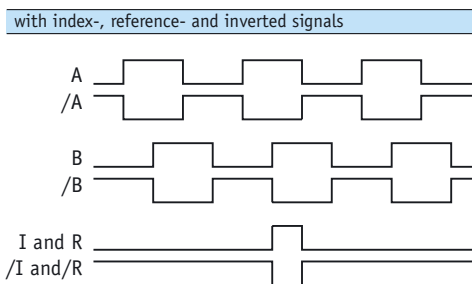

Pulse interval

The pulse distance "t" is the shortest time period which can occur between two signal edges when moving the magnetic sensor. Micro vibration can trigger it for example. It must be made sure that the follower electronics is able to correctly process the signals.

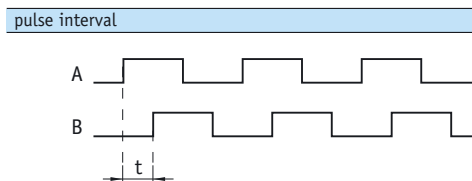

Example: pulse interval $t = 1 \mu s$

$$\text{input frequency} = \frac{1}{1 \mu s \cdot 4} = 250 \text{ kHz}$$

The follower electronics must be able to work with 250 kHz.

Appendix: Calculation tables

Impulses/turn

The calculation of the impulses/turn is dependent on the number of poles and the scaling factor and is calculated with the formula:

$$\text{impulses/turn} = \text{Scaling factor} \times \text{pole pitch}$$

MR320 and MSK320

Impulses/turn				Scaling factor
2000	3000	3600	5000	20
1600	2400	2880	4000	16
1000	1500	1800	2500	10
800	1200	1440	2000	8
500	750	900	1250	5
400	600	720	1000	4
100	150	180	250	1
100	150	180	250	pole pitch

MRI01 and MSK320

Impulses/turn				Scaling factor
1280				20
1024				16
640				10
512				8
320				5
256				4
64				1
64				pole pitch

MR200 and MSK210

Impulses/turn			Scaling factor
1000	1280	2000	20
800	1024	1600	16
500	640	1000	10
400	512	800	8
250	320	500	5
200	256	400	4
50	64	100	1
50	64	100	pole pitch

MR500 and MSK500/1

Impulses/turn			Scaling factor
16000	24000	40000	250
8000	12000	20000	125
6400	9600	16000	100
4000	6000	10000	62.5
3200	4800	8000	50
1600	2400	4000	25
800	1200	2000	12.5
64	96	160	pole pitch

MR200

Pole pitch	U [m]	n [1/min]
50	0.1	15 000
64	0.13	11 500
100	0.2	7 500

MR320

Pole pitch	U [m]	n [1/min]
100	0.32	4687.50
150	0.48	3125.00
180	0.57	2631.00
250	0.80	1875.00

MRI01

Pole pitch	U [m]	n [1/min]
64	0.157	9554.14

MR500

Pole pitch	U [m]	n [1/min]
64	0.32	variable
96	0.48	variable
160	0.80	variable

Rotational Speed

The calculation of the maximum rotational speed takes place with respect to the circumferential speed where the circumference of the magnetic ring used is decisive. For the MSK320 sensor, the circumferential speed is 25 m/s whereas the speed for the MSK500/1 sensor is variable and results from the selection of the pulse interval and the scaling factor (see MSK500/1 table).

The rotational speed is calculated with the formula:

$$\text{rotational speed } n = \frac{v \cdot 60}{U}$$

v = circumferential speed [m/s]; U = circumference[m]

60 = expansion factor [60 s/min]

$$\text{MSK320 for instance: } n = \frac{25 \cdot 60}{0.32} = 4687.50 \text{ [1/min]}$$

$$\text{MSK500/1 for instance: } n = \frac{6 \cdot 60}{0.32} = 1125 \text{ [1/min]}$$

Appendix/Pin outs

MSK210 + MSK320 + MSK500

Connection type E1



Connection type E6



Connection type E8



Signals not inverted (only MSK320)

PIN (E8)	PIN (E6)	Color (E1)	Signal
1	1	black	GND
2	2	brown	+UB
3	3	red	A
4	4	orange	B

Signals inverted

PIN (E8)	PIN (E6)	Color (E1)	Signal
1	1	red	A
2	2	orange	B
3	3	-	N.C.
4	4	brown	+UB
5	5	black	GND
6	6	yellow	A/
7	7	green	B/

Signals inverted with reference signal

PIN (E8)	PIN (E6)	Color (E1)	Signal
1	1 (A)	red	A
2	2 (B)	orange	B
3	3 (C)	blue	I
4	4 (D)	brown	+UB
5	5 (E)	black	GND
6	6 (F)	yellow	A/
7	7 (G)	green	B/
8	8 (H)	violet	I/

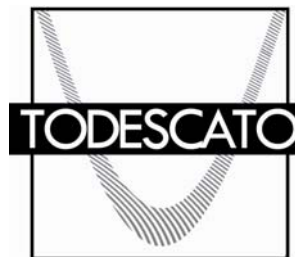

Indirizzo
Via A. Palladio, 13/e
36040 SAREGO - VI
Telefono
340-8102809
Telefax
0444-820426
Email
info@todescato.com
Internet
www.todescato.com

Rappresentanze prodotti per automazione industriale